

Compact Mounting Envelope

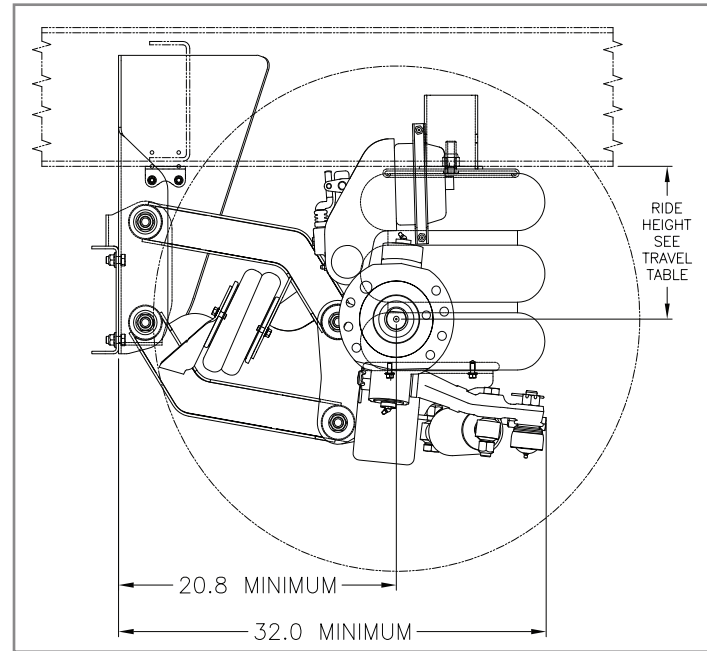

TRAVEL TABLE 233 LM

RIDE HEIGHT	NO SPACER		1" SPACER		2" SPACER	
	UP	DOWN	UP	DOWN	UP	DOWN
7.00	6.0	7.0	—	—	—	—
7.50	6.5	6.5	—	—	—	—
8.00	7.0	6.0	6.0	7.0	—	—
8.50	7.5	5.5	6.5	6.5	—	—
9.00	8.0	5.0	7.0	6.0	6.0	7.0
9.50	8.5	4.5	7.5	5.5	6.5	6.5
10.00	9.0	4.0	8.0	5.0	7.0	6.0
10.50	9.5	3.5	8.5	4.5	7.5	5.5
11.00	10.0	3.0	9.0	4.0	8.0	5.0
11.50	—	—	9.5	3.5	8.5	4.5
12.00	—	—	10.0	3.0	9.0	4.0
12.50	—	—	—	—	9.5	3.5
13.00	—	—	—	—	10.0	3.0

TRAVEL TABLE 233 MM

RIDE HEIGHT	NO SPACER		1" SPACER		2" SPACER	
	UP	DOWN	UP	DOWN	UP	DOWN
10.00	6.0	7.0	—	—	—	—
10.50	6.5	6.5	—	—	—	—
11.00	7.0	6.0	6.0	7.0	—	—
11.50	7.5	5.5	6.5	6.5	—	—
12.00	8.0	5.0	7.0	6.0	6.0	7.0
12.50	8.5	4.5	7.5	5.5	6.5	6.5
13.00	9.0	4.0	8.0	5.0	7.0	6.0
13.50	9.5	3.5	8.5	4.5	7.5	5.5
14.00	10.0	3.0	9.0	4.0	8.0	5.0
14.50	—	—	9.5	3.5	8.5	4.5
15.00	—	—	10.0	3.0	9.0	4.0
15.50	—	—	—	—	9.5	3.5
16.00	—	—	—	—	10.0	3.0

TRAVEL TABLE 233 HM

RIDE HEIGHT	NO SPACER		1" SPACER		2" SPACER	
	UP	DOWN	UP	DOWN	UP	DOWN
12.00	6.0	7.0	—	—	—	—
12.50	6.5	6.5	—	—	—	—
13.00	7.0	6.0	6.0	7.0	—	—
13.50	7.5	5.5	6.5	6.5	—	—
14.00	8.0	5.0	7.0	6.0	6.0	7.0
14.50	8.5	4.5	7.5	5.5	6.5	6.5
15.00	9.0	4.0	8.0	5.0	7.0	6.0
15.50	9.5	3.5	8.5	4.5	7.5	5.5
16.00	10.0	3.0	9.0	4.0	8.0	5.0
16.50	—	—	9.5	3.5	8.5	4.5
17.00	—	—	10.0	3.0	9.0	4.0
17.50	—	—	—	—	9.5	3.5
18.00	—	—	—	—	10.0	3.0

**RIDEWELL
SUSPENSIONS**

RSS-233 10K Truck

Self-Steering Auxiliary Axle Suspension

A Lightweight Suspension Without Sacrificing Durability

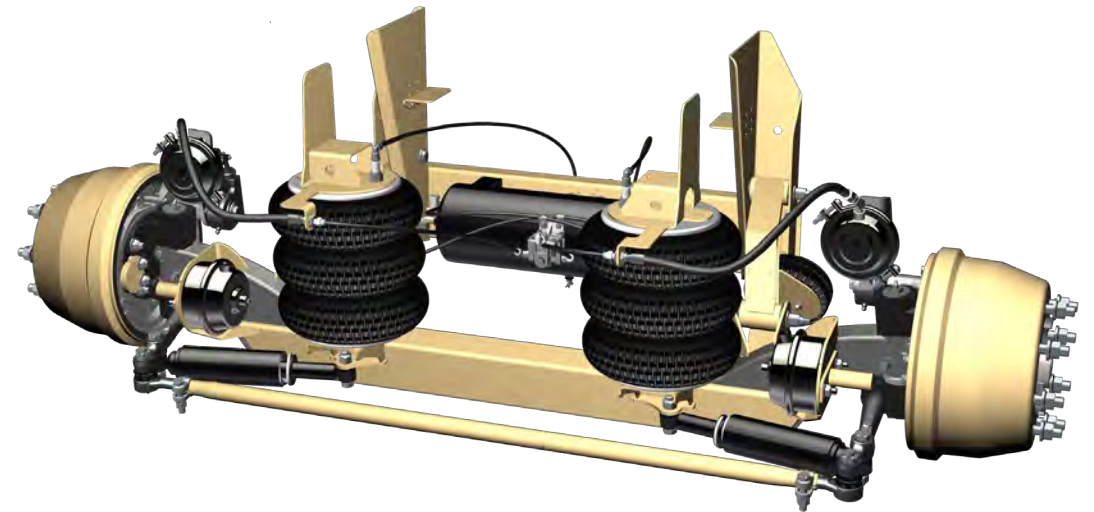

RSS-233
10,000 lb Capacity

5 year limited warranty

13" total travel, maximum of 10" lift

Compact mounting envelope

Assembled with huck fasteners for reduced maintenance

Pre-plumbed air tank option

For questions or to place an order, contact
HAWKEYE TRUCK EQUIPMENT
515-289-1755 or 1-800-622-8223

SS-233 10 K Auxiliary Steerable Lift Axle

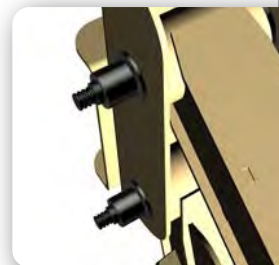
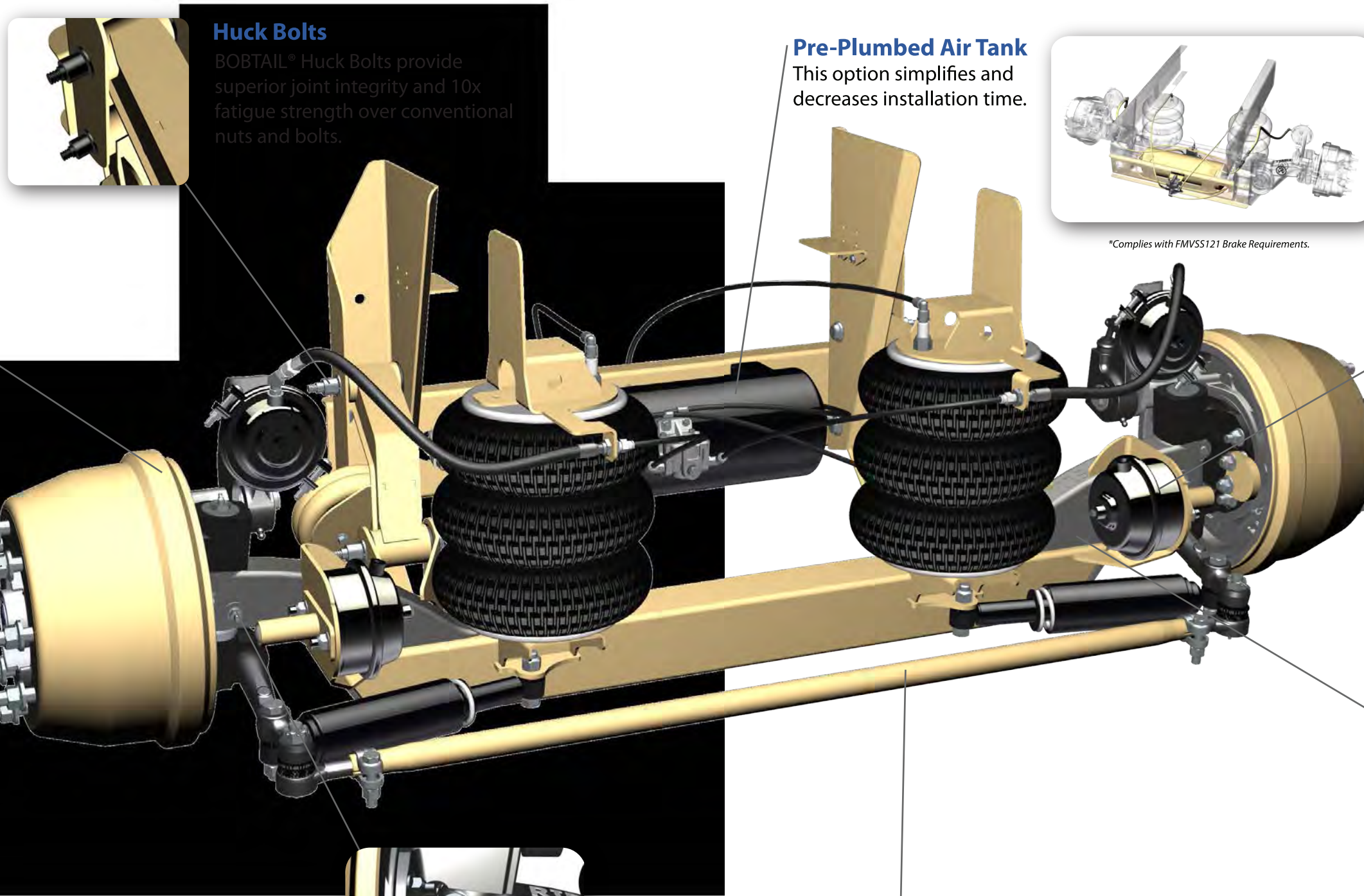

Huck Bolts
BOBTAIL® Huck Bolts provide superior joint integrity and 10x fatigue strength over conventional nuts and bolts.

Pre-Plumbed Air Tank
This option simplifies and decreases installation time.

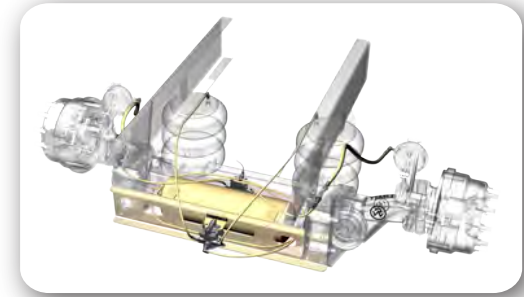

*Complies with FMVSS121 Brake Requirements.

Steer Knuckles
Forged one-piece steer knuckles. All wheel end parts are industry standard for simple replacement.

Steer Locks
Unique design positively locks on both wheel ends in the straight position. Can be activated at any wheel angle position.

Wheel Ends
8 stud hub to accommodate 19.5" wheel and tire

Fully Cast Axle Ends
This durable design adds strength to the critical axle transition area.



Industry Standard Tie Rod
This traditional tie rod tube, keeps wheel ends in alignment, extending tire life.



Dual Draw Key King Pin Design
This design fully captures the king pin within the axle end for longer service life and less down time.

- Additional Features:**
- Forged, one-piece, steer knuckles
 - Suspension ships fully assembled
 - 7"-18" ride heights
 - 31.2 degree wheel cut
 - Offset control arms for improved lateral stability

For questions or to place an order, contact
HAWKEYE TRUCK EQUIPMENT
515-289-1755 or 1-800-622-8223